

Accelerometer AT512

Temperature Range - 50 to 121 °C

Sensitivity 500 mV/g

Technical Specification

Frequency Response	0.2-3 000 Hz \pm 3dB
Dynamic Range	\pm 10 g, peak
Current Excitation	2-10 mA
Bias Voltage	10-14 VDC
Sealing	Welded, Hermetic
Weight	95 g
Material	316L Stainless Steel
Mounting	M6
Connector	2 Pin MIL-C-5015
Mounted Resonance	12 000 Hz (nom.)
Mounting Torque	2.7 to 6.8 Nm

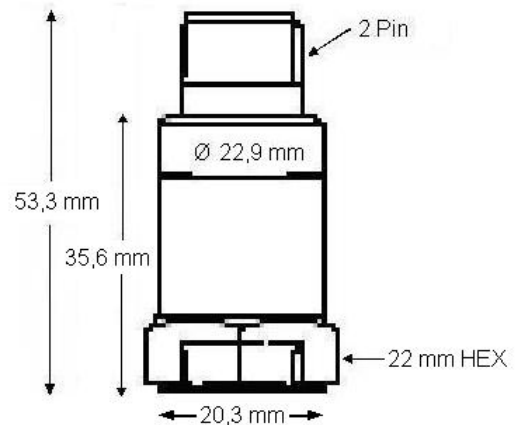

Mounting / Order Code

Standard (Top Connected)	Order Code AT512
Integral Cable	Order Code AT512-I
Armored Integral Cable	Order Code AT512-AI

Applications

Motors	Cooling Towers
Compressors	Gear Boxes
Fans	Pumps
Presses	Spindles
Process Equipment	Etc.