

Accelerometer AT112

Temperature Range - 50 to 121 °C

Sensitivity 100 mV/g

Technical Specification

Frequency Response	0.5–15 000 Hz ± 3dB
Dynamic Range	± 50 g, peak
Current Excitation	2-10 mA
Bias Voltage	10-14 VDC
Sealing	Welded, Hermetic
Weight	90 g (nom.)
Material	316 L Stainless Steel
Mounting	M6
Connector	2 Pin MIL-C-5015
Mounted Resonance	23 000 Hz (nom.)
Mounting Torque	2,7-6,8 Nm

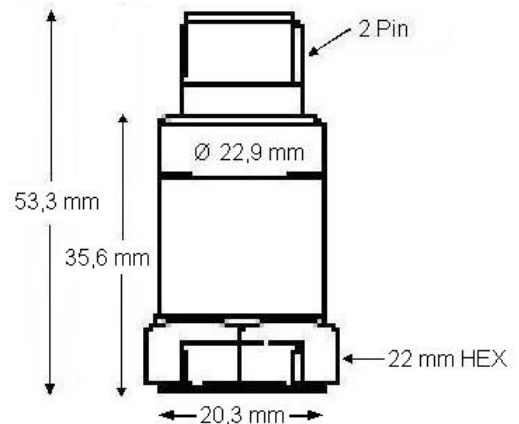

Mounting / Order Code

Standard (Top Mounted)	Order Code: AT112
Integral Cable	Order Code: AT112-I
Armored Integral Cable	Order Code: AT112-AI

Applications

Motors	Cooling Towers
Compressor	Gear Boxes
Fans	Pumps
Presses	Spindles
Process Equipment	Etc.