

## Accelerometer AT112-LC

Temperature Range - 50 to 121 °C

Sensitivity 100 mV/g

### Technical Specification

Frequency Response	1-10 000 Hz ± 3dB
Dynamic Range	± 50 g, peak
Current Excitation	2-10 mA
Bias Voltage	10-14 VDC
Sealing	Welded, Hermetic
Weight	90 g (nom.)
Material	316 L Stainless Steel
Mounting	M6
Connector	2 Pin MIL-C-5015
Mounted Resonance	23 000 Hz
Mounting Torque	2,7-6,8 Nm

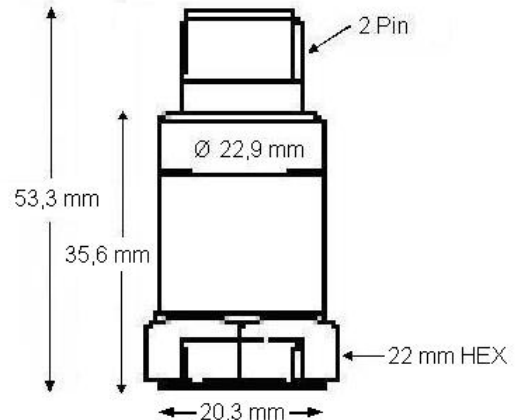

### Mounting / Order Code

Standard (Top Connected)	Order Code: AT112-LC
Integral Cable	Order Code: AT112-LC-I
Armored Integral Cable	Order Code: AT112-LC-AI

### Applications

Motors	Cooling Towers
Compressors	Gear Boxes
Fans	Pumps
Presses	Spindles
Process Equipment	Etc.